

Approved for public release; distribution is unlimited.

## **Improving Attachments of Non-Invasive (Type III) Electronic Data Loggers to Cetaceans**

Michael Moore (PI), Alex Shorter, Mark Johnson, Peter Tyack, Tom Hurst, Alessandro Bocconcelli

Woods Hole Oceanographic Institution,  
Woods Hole, MA 02543

Dan Rittschof, Douglas Nowacek  
Nicholas School of the Environment, 135 Duke Marine Lab. Rd.,  
Beaufort, NC28516

Laurens Howle  
BelleQuant Engineering PLLC  
7813 Dairy Ridge Rd, Mebane, NC 27302

Contact: M Moore - phone: 508 289 3228 fax 508 457 2089  
email [mmoore@whoi.edu](mailto:mmoore@whoi.edu)

Award Number: N00014-11-1-0113

<http://www.whoi.edu>

### **LONG-TERM GOALS**

The overall goal of this project is to increase the longevity of suction cup attachments for short term archival tags such as the DTAG. Specifically, we are working to extend the routine attachment duration for suction cup tags to multiple days, if not weeks. Methods will be developed to extend tag attachment by streamlining tag housings, selecting appropriate materials for tag/cup assembly, improving suction cup design, understanding the behavior of the attachment surface during attachment, and investigating the possible use of adhesives.

### **OBJECTIVES**

- 1) Examine and identify forces and failure modes in suction cup attachments.
- 2) Assess the impact of tags and non-invasive surface attachments on cetaceans.
- 3) Take the knowledge gained from objectives 1) and 2) and engineer suction cups and surface treatments for improved attachment.
- 4) Examine on-animal performance of engineered attachments and tags.

## **APPROACH**

Our approach is divided into tasks designed to accomplish the objectives listed above.

**Task 1: Forces and failure modes in suction cup attachments.** Define assays to investigate cup failure modes. This will include development of an instrumented cup that will measure skin intrusion into the cup during attachment. Effects of pressure will be modeled on and validated using the instrumented cup and cadavers in the WHOI hyperbaric CT chamber. Microstructure and biochemistry of cetacean skin will also be evaluated.

**Task II: Assessing the impact of tags and surface attachments on cetaceans.** Using Computational Fluid Dynamics we will assess the lift and drag forces created by various suction cup and tag housing combinations. This modeling work will be used to design a tag that minimizes lift and drag while still maintaining the functionality of the electronic data-logging tag. Using histology we will evaluate the impact of suction cup attachment on the skin and blubber of freshly dead cadavers. We will deploy the instrumented cup on captive and stranded cetaceans to assess the impact of the suction cup attachment on the animal.

**Task III: Engineered suction cups and surface treatments for improved attachment.** In the light of Tasks I and II we will engineer suction cups with longer duration using selected materials and molding techniques, and cup surface treatments, and investigate the use of adhesives. The engineered cup will be integrated into the tag housing design to maximize the duration of attachment.

**Task IV: On-animal performance of engineered attachments and tags.** Using free swimming animals, first in captivity and then on stranded releases and animals tagged at sea, we will attach the engineered system with an instrumented cup to test cup behavior and longevity. We will assess impact on the animal by analysis of DTAG derived energetics and behavioral data.

## **WORK COMPLETED**

### **Task I: Cup Testing at Sarasota Dolphin Research Program Capture-Release - May 2011**

**Objective:** To document the behavior of suction cups on live bottlenose dolphin skin, using diverse cups, some instrumented with a manometer, photography and ultrasound scanning.

**Method:** The target area of the skin was scanned with ultrasound (GE Voluson i portable ultrasound unit; 2-5 MHz RAB 3D/4D volume transducer) to acquire a baseline image. DA-PRO or shin-etsu semi-transparent cups were then attached. Pressure under the cup was recorded every minute until the cups were removed, after 20-30 minutes. The morphology of the resultant impression on the skin was then recorded photographically. The area where the cup had been attached and adjacent skin was then scanned with ultrasound. Where the cup wall was semi transparent the shape of the domed skin inside the cup was also recorded photographically. For later animals in the series, DTAG-3 semi-transparent cups with and without a manometer attached were also tested.

**Results:** Cup behavior was documented on 14 animals.

1. No change in pressure with time was observed with the cups instrumented with a manometer. The pressure was consistent within 1-1.5 psi for the Shinetsu RTV silicone cup, 0.5 to 1.0 psi for the DA/PRO rubber cup and 0.9 to 1.4 psi for the DTAG3 cups. There was no consistent change in pressure with time.

2. Ultrasound images are still being evaluated but no marked changes were observed. When the attached cup was ultrasound-scanned through the periphery of the cup, lateral to the bubble, it was clear that the skin and underlying dermis was domed up into the cup.

3. Photographic images of the attached cups showed a marked doming of the skin into the cup as suggested by the above ultrasound observation (Figure 1). Images from above the cup also showed variable behavior of the air bubble in the dome of the cup (Figure 2). Sometimes it was coalesced into a single circular edged bubble, other times it's perimeter was randomly shaped, and other times there were additional multiple small dispersed air pockets that the coalesced into the center bubble. The size of the bubble was measured through time. In different cases, it grew, shrank or remained stable. It was also notable that immediately after the cup was removed the domed skin sprang back to almost a flush surface, with just a small raised dimple where the cup had been (Figure 3).

The results from these experimental observations will motivate and focus future work for Tasks 1 and 2. Specifically, these results will be used to refine the assays to investigate cup failure modes, and aid in the development of the instrumented cup to directly measure the intrusion into the cup during attachment. Field results from live animals will also be used to inform future work with captive and stranded cetaceans when assessing the impact of the suction cup attachment on the animal.

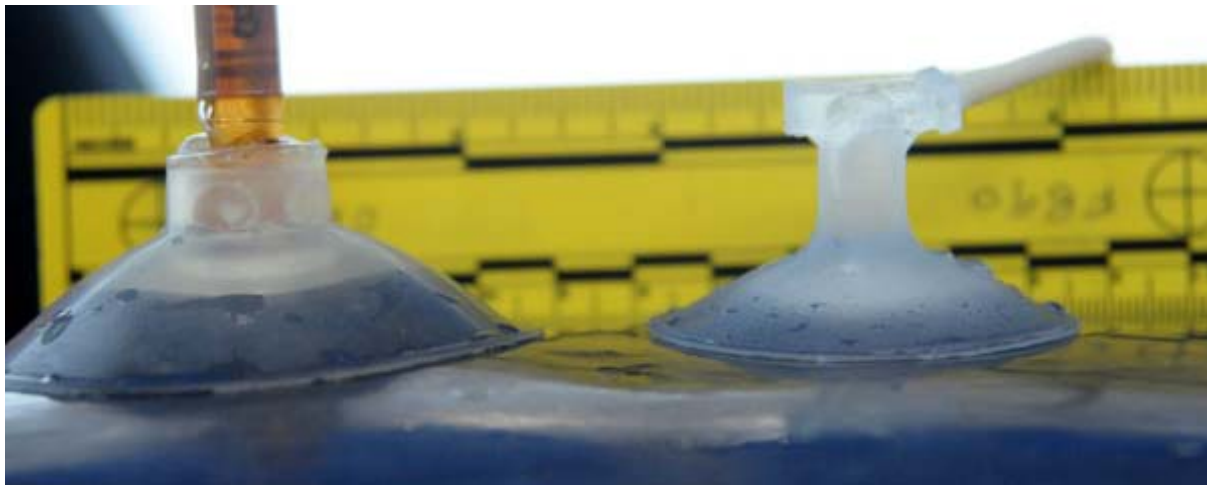

Figure 1. Shinetsu silicone cup on left, DTAG3 cup on right on live bottlenose dolphin skin after 20 minutes of attachment. Note that the smaller cup pulls less of a dome of skin.



Figure 2. Top panel shows three DTAG3 cups at the time of application. Note peripheral air pockets in addition to the central bubble. Bottom panel 14 minutes later. The peripheral bubbles have coalesced into the central bubble. Where the central bubble margin is irregular in the top panel, that irregularity is preserved at the later time.



Figure 3 - Skin after removal of DTAG3 cups showing very slightly raised areas where the cups had been.

**Acknowledgement:** many thanks to Randall Wells, and the Chicago Zoological Society for the opportunity to undertake this work. The work was conducted under NOAA permit 14241 issued to Dr Peter Tyack.

## Task II: CFD modeling for improved tag design

**Objective:** During tag attachments, lift, drag, and side forces can remove the instrument or adversely affect the behavior or energetics of the animal. As such, tag packaging must minimize the fluid dynamic forces generated by fluid flow. Hydrodynamic force loading of many variants of suction cup tags were analyzed using computational fluid dynamical (CFD) modeling to determine forces and to inform on future packaging designs.

**Method:** A CFD model was used to analyze the forces acting on the DTAG over a range of flow velocities (0.25-10 m/s) and flow orientations (0-180 deg) using steady RANS flow field simulations. Flow fields around 3D CAD models of the tag were simulated using the SolidWorks 2011 Flow Simulation package. The simulations were run in parallel on a dual quad-core (8 cores total) computer with 32 GB of RAM. The use of computational modeling greatly accelerates the design process because it provides access to information that might be unavailable in a purely experimental evaluation of the system. Further, the development of the tag packaging in this environment allows the designers to address issues critical to the performance of the system well before the device is ever used on an animal.

**Results:**

Figures 4 and 5 show results from a simulation with a steady fluid flow velocity of 5 m/s with the DTAG V1.0 aligned with the flow (0 deg). The simulated drag was 2.6 lbf acting in the direction of the flow, and the lift was 27.6 lbf acting on the tag body perpendicular to the attachment surface. The DTAG V1.0 simulation results also show that off-axis flow over the tag can result in a doubling of the drag force, and that the drag and lift forces increase significantly as the velocity was increased to 10 m/s (10.6 lbf and 110.4 lbf respectively). Both Figures 4 and 5 show key regions of reduced fluid velocity ahead of the tag, behind the tag, and between the suction cups that generate the drag and lift on the tag. Figure 5, details only the stream lines acting on the stems and leading edge of the front cup, and clearly shows the undesirable effect of the cup geometry on the fluid flow.

The identification of undesirable tag geometry lead to a redesign of the tag packaging (DTAG3 V1.1) that significantly reduced the drag and lift forces acting on the tag. Figure 6 shows the DTAG V1.1 aligned with a steady flow of 5 m/s. The new tag packaging, based on the bio-inspired shape of the North Atlantic horseshoe crab, *Limulus polyphemus*, has a minimum number of geometric disruptions to the flow to reduce drag, and a channel to control flow under the tag to reduce lift. The resulting lift and drag on the tag were 0.9 lbf and 5.8 lbf respectively.

Models of both DTAG3 V1.0 and V1.1 will be fabricated and used to validate the simulation results in experimental water tunnel testing at the United States Naval Academy. The improvements to the tag packaging have the potential to contribute to both increased tag attachment times and to reduce the parasitic impact to the tagged animal. CFD modeling will also continue to enable the tag designer to quickly evaluate and iterate tag designs in a relatively accurate virtual environment, reducing design effort and expense.

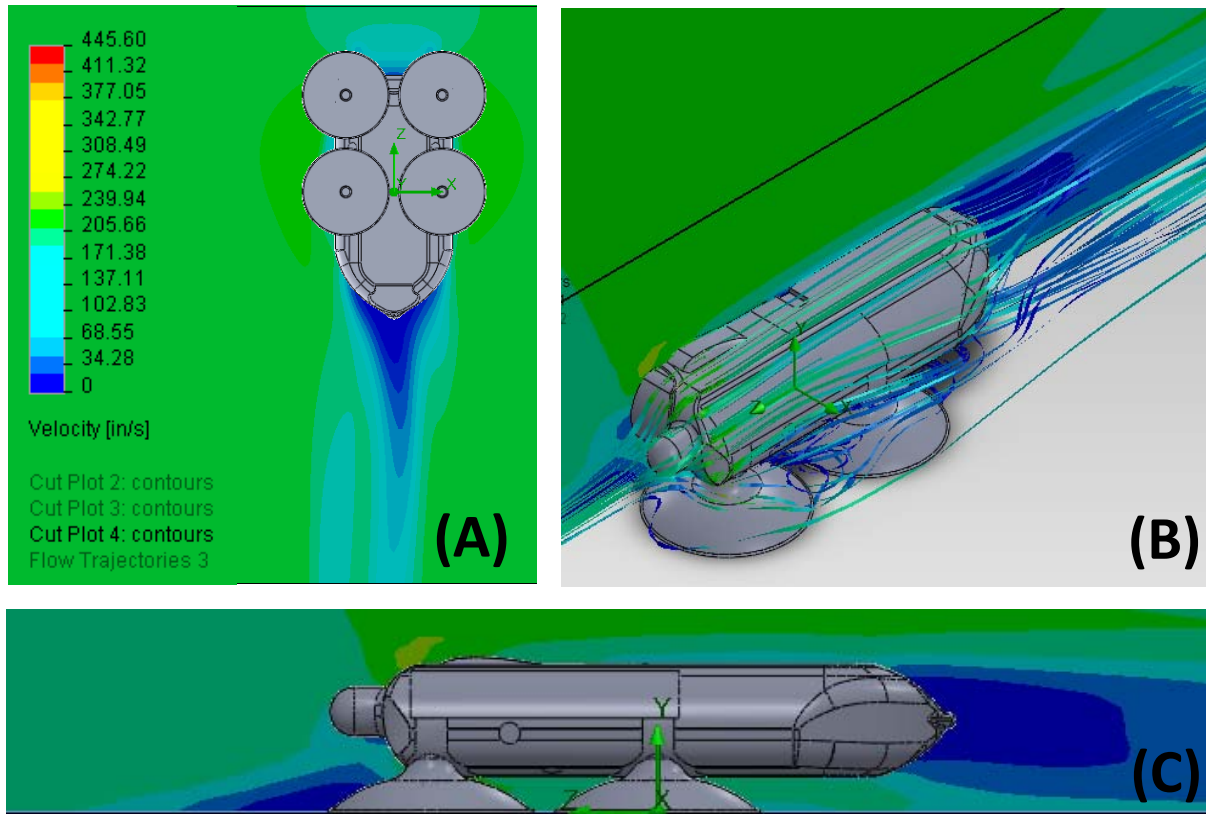

**Figure 4** CFD modeling results for the current version of the DTAG during steady 5 m/s flow. The blue regions are areas of reduced fluid speed that result in drag forces acting on the tag. **(A)** Bottom view of a cross section of the fluid velocity at the tag midline that shows the reduction of fluid velocity ahead (damming affect) and behind the tag (bluff body wake). **(B)** Selected stream lines that show the disruption to the flow caused by the suction cup geometry. **(C)** Side view of a cross section of the fluid velocity that shows areas of reduced fluid velocity ahead of the tag and behind the tag.

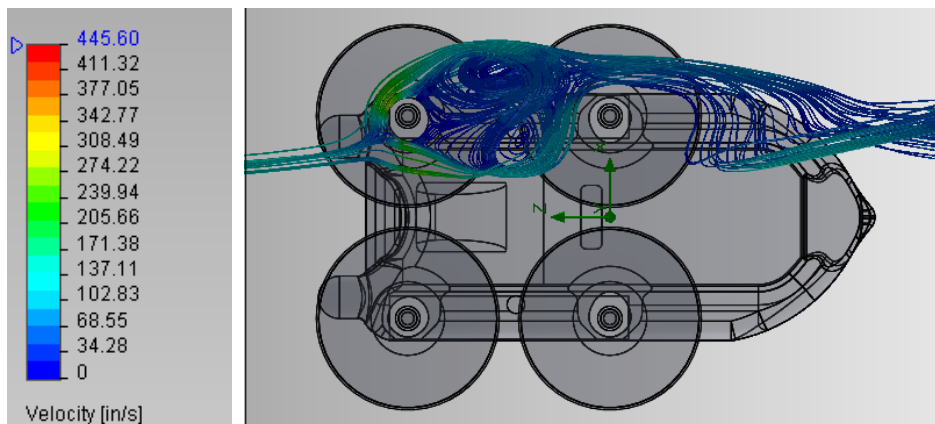

**Figure 5** A detail of select stream lines that show the disturbance created by the suction cups in the fluid flow. The eddies and reduced fluid velocity result in larger forces acting on the tag.

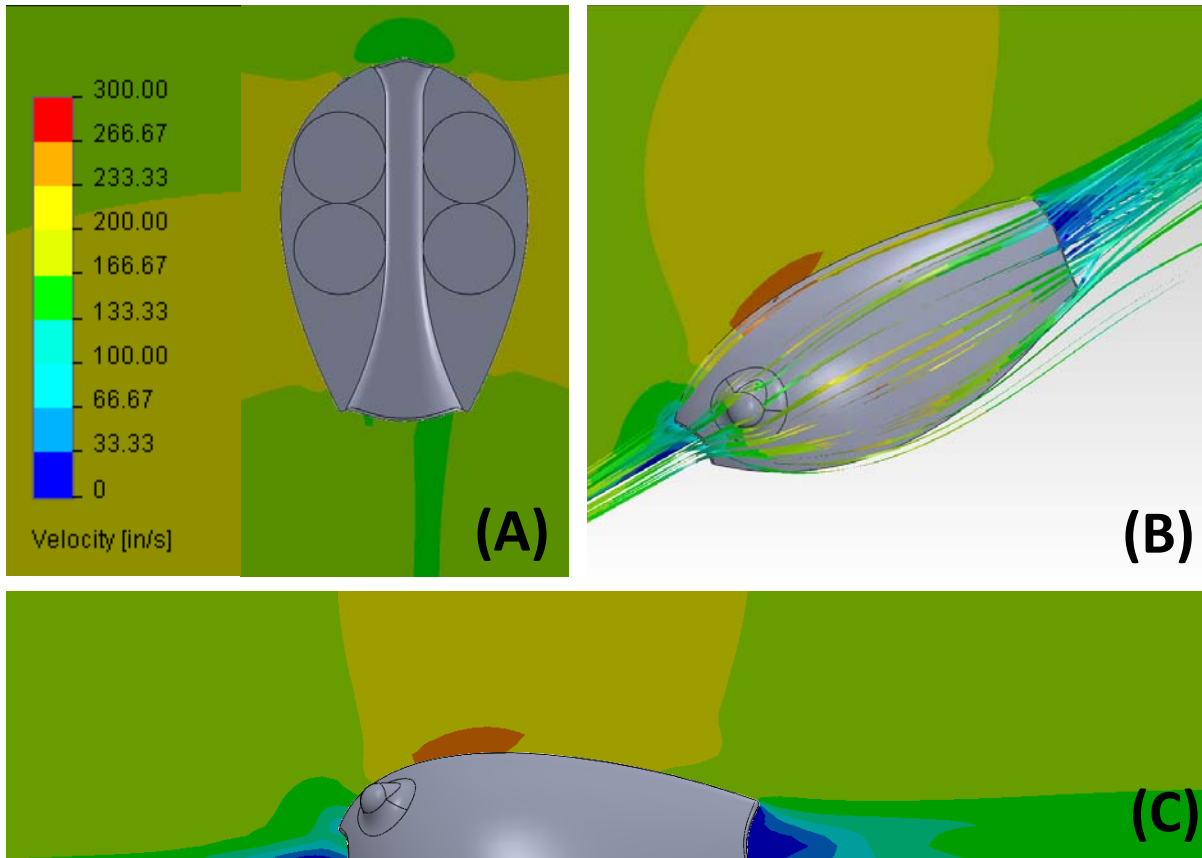

**Figure 6** CFD modeling results for the redesigned DTAG V1.1 packaging during steady 5 m/s flow. The modified shape has improved the flow around the tag in all three subplots, when compared to Figure 4. **(A)** Bottom view of a cross section of the fluid velocity at the tag midline that shows a significant reduction of the damming affect and bluff body wake created by the V1.0 design. **(B)** The improved design eliminates the disruption to the flow caused by the cup geometry. **(C)** Side view of a cross section of the fluid velocity that shows the improved flow around the tag, and the effect of the channel under the tag.

### **Task III: Engineered suction cups and surface treatments for improved attachment**

#### **A) Micro texturing of the suction cup to reduced leakage:**

**Objective:** Use microtexturing to create a superhydrophobic barrier between the lip and the internal volume of the cup to block fluid ingress and improve cup attachment performance.

**Method:** Surface roughening techniques can increase the surface area of a solid, thereby amplifying the natural hydrophobicity of a surface. Superhydrophobicity is created by interfacial tension forces that suspend water on the tops of micro- and nanoscale pillars, allowing the water to roll off the structured surface when tilted only a few degrees. These textured surfaces have also been observed resisting the flow of water over a level surface. For the cup, compression of

micropillars against the attachment surface will create a hydrophobic barrier between the lip and internal volume of the cup that will resist fluid ingress. The nature of the texturing also has the potential to eliminate leakage pathways that might otherwise exist as surface defects in the cups.

**Results:** A successful cup prototype was fabricated with 5 micron diameter micropillars molded into the cup surface using a modified DTAG3 cup mold, a plastic insert with the mold negative, and a poured RTV, Figure 7. The plastic insert consisted of a 5 mm wide ring of PDMS with the micro-textured negative. The ring was glued into a corresponding ringed cutout of the delrin base of the standard DTAG3 cup mold. The proof of concept part fabricated with this mold assembly was successfully micro-textured, but the fabrication process needs to be improved before cups suitable for formal evaluation and testing can be made. The major shortcoming of the current fabrication process is the additional undesirable feature that was created on the interior surface of the lip, Figure 8. This undesirable feature was caused by the difficulty of cutting and gluing the PDMS ring into the mold.

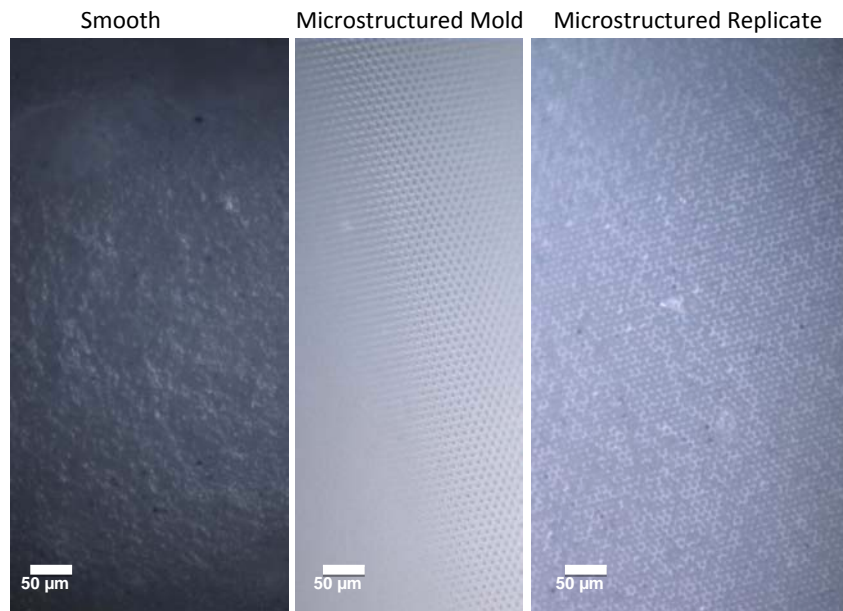

**Figure 7** Untextured cup surface (left), mold surface (center), and textured cup surface (right).

These successful preliminary results will be used to inform the next generation of micro-textured cup. To address the undesirable feature on the surface of the cup lip a casting process will be to create a micro-textured nickel cap that can be fixed to the cup mold to provide a uniform surface for the interior of the cup. A comparison between textured and nontextured suction cups will be performed, and the casting fidelity of the micropillars on the silicone suction cups will be evaluated. Additionally, micro-texturing patterns will be explored, Figure 9.



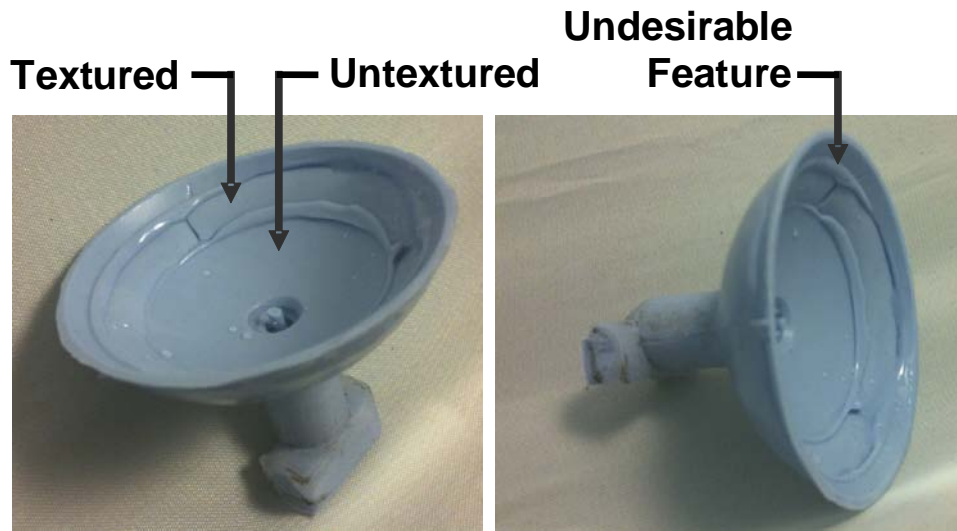

**Figure 8** The RTV cup prototype with the 5 mm micro-textured ring. The undesirable macro-surface feature created by the current mold is also shown.

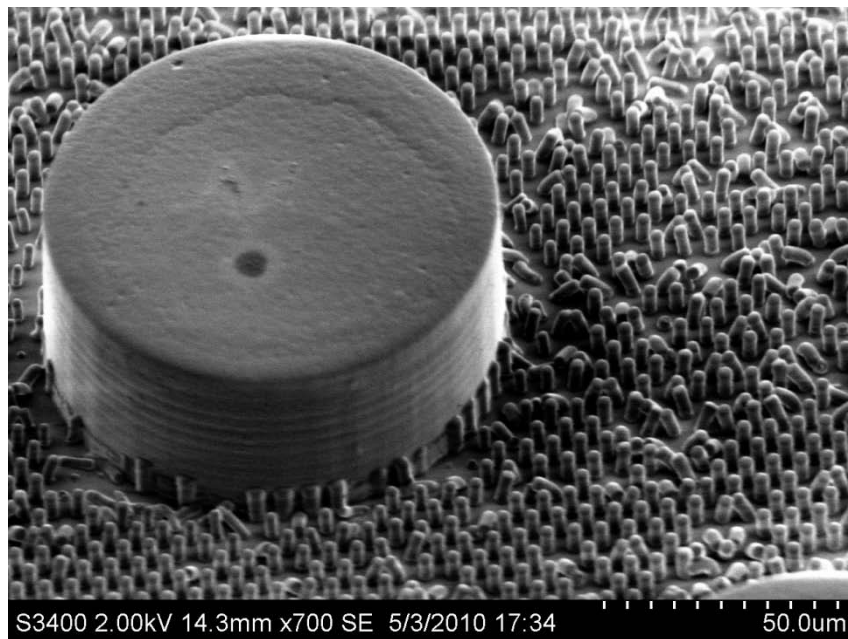

**Figure 9** An SEM image that illustrates how texturing of different sizes can be applied to the same surface. In the image 2.5 micron diameter pillars are shown surrounding a larger 100 micron diameter pillar.

## **The use of adhesives to improve cup performance:**

**Objective:** Utilize a rapid curing topical glue to extend the longevity of noninvasive tag attachments to tens of days without harmful effects to the animal by gluing to the dead layers of external skin that are eventually sloughed.

**Method:** Initially, this project focused on the development of a biological glue based upon barnacle glue. The barnacle glue polymerization process has the same enzymatic process as blood coagulation. Synthetic barnacle glue was developed based on the biochemistry of barnacle glue; transglutaminase, poly-lysine, and glutamic acid. Our initial studies showed that in cold water enzymatic curing results in poor adhesion and causes the adhesive to cure too slowly for an application where the animals begin to swim immediately after the initial application of the glue. To address this issue, a cyanoacrylate which quickly polymerizes and generates strong adhesive bonds catalyzed by water was selected. Additionally, there are selections of medical grade cyanoacrylates glues for use in veterinary animals and humans. We conducted studies on the adhesive strength of cyanoacrylate on a chicken skin model and subsequently on skin/blubber samples from stranded dolphins and a sperm whale.

**Results:** We found cyanoacrylate polymerized in less than 5 minutes on all skins. Attachment strength was even substantial on the sperm whale skin which was sloughing its epithelium in sheets. We found the force applied during application was related to adhesion strength. Adhesion strength increased between application forces of 1 and 10 N·cm<sup>2</sup> (10 N is the strength of a firm handshake). Application forces above 10 N did not create stronger adhesion. Using pseudo barnacles (stainless steel 1.5 in bolts) we determined that an object glued to dolphin and whale skin remained securely attached to the underlying skin and that shear force to generate failure would require speeds greater than 20 knots. Failure was adhesive, between the patch and the skin, rather than cohesive (between the layers of living skin). Blotting the skin to dry the attachment site resulted in very strong attachment but the glues also worked effectively with damp skin.

Thus, the cyanoacrylate glues examined thus far show great promise for this application. At present we are examining flexible attachment surfaces instead of the 1 cm squared pseudo barnacle used in preliminary tests. The present whale model is a wet, smooth exercise ball that we can spin in a tank of water and then attempt to attach a flexible patch with cyanoacrylate glue. Once we have worked this technique out, we will go back to testing skin from stranded animals for ability to attach. When this technique is worked out, we will make a full scale tags and test them on a dead stranded whale.

## **Impact, Applications and Transitions**

### ***National Security***

Better understanding of the interaction between acoustic stressors and whales and dolphins is critical for enabling sonar training exercises. Enhanced data logging tag durability using engineered suction cups will enable this understanding.

### ***Economic Development***

Enhanced duration of suction cup attachment duration will broaden the potential for data logging tags designed to better understand marine mammal behavior, without invasive attachment systems.

### ***Quality of Life***

Better understanding of marine mammal behavior in the context of industrial and security operations will enhance ecosystem level viability, by enabling impact mitigation.

### ***Science Education and Communication***

This study is generating a number of manuscripts for peer reviewed publication.

The following abstract has been accepted by the Society for Marine Mammalogy Annual Biennial Meeting in Orlando, November 2011 as a talk. **Program Topic:** New Technology » New Technology

### **Modeling and analysis of fluid flow around a suction cup bio-logging tag**

**Authors:** K. Alex Shorter<sup>1</sup>, Laurens Howle<sup>2</sup>, Mark Johnson<sup>3</sup>, Doug Nowacek<sup>4</sup>, Tom Hurst<sup>5</sup>, Alessandro Bocconcelli<sup>5</sup> and Michael Moore<sup>1</sup>.

<sup>1</sup> Biology Department, Woods Hole Oceanographic Institution, Woods Hole, MA 02543, USA.

<sup>2</sup> Pratt School of Engineering, Duke University, Durham, NC 27708, USA.

<sup>3</sup> School of Biology, University of St. Andrews, Gatty Marine Laboratory, St Andrews, Fife KY16 8LB UK.

<sup>4</sup> Nicholas School of the Environment and Pratt School of Engineering, Duke University—Marine Laboratory, 135 Duke Marine Lab Rd., Beaufort, NC 28516, USA.

<sup>5</sup> Applied Ocean Physics and Engineering, Woods Hole Oceanographic Institution, Woods Hole, MA 02543, USA.

### **Abstract:**

As sensing and electronic technology has improved, the use of bio-logging tags for the study of marine mammals has steadily grown. These tags require the electronics to be packaged in a housing that protects it from the environment, maintains proper configuration of the sensors, and provides a means of attachment to the animal. The packaging must provide this functionality in a hydrodynamic form to minimize the forces generated by fluid flow. These forces can remove the tag or adversely affect the behavior or energetics of the animal. Despite the recent advancements in electronics technology, sophisticated analysis and design of the packaging has been lacking. In this work, drag loading of a suction cup tag was analyzed using a computational fluid dynamical (CFD) model. The CFD model was used to analyze the forces acting on the tag over a range of flow velocities and flow orientations. The results from the analysis identified key features of the tag geometry around the suction cups that can be changed to reduce drag by up to 60% in simulation. Additionally, off-axis flow over the tag can result in a doubling of the drag force. The simulation results were validated in an experimental water tunnel. The use of computational modeling accelerates the design process because it provides access to information that might be unavailable in a purely experimental evaluation of the system. These models also enable the

designer to quickly evaluate and iterate tag designs in a relatively accurate virtual environment, reducing design effort and expense. Further, the development of the tag packaging in this environment allows the designers to address issues critical to the performance of the system well before the device is ever used on an animal. This work was supported by NOPP with NSF funds through ONR Grant N00014-11-1-0113.